

# Front upper control arm bushes

## Application:

### - Ford Falcon FG Series

Always refer to current catalogue for complete application listing.

## Contents:

- 4 x 67057 Bushes
- 4 x Crush tubes
- 1 x Grease sachet

## Fitting Instructions:

Please read complete fitting instructions and check kit components prior to fitment. These instructions are to be used in conjunction with the workshop manual, and it is recommended that all work be carried out by a qualified technician.

1. Raise and support the vehicle on chassis stands.
2. Remove the road wheels from the vehicle.
3. Remove the upper ball joint clevis bolt from the knuckle .
4. Gain access to the inner control arm bracket mount nuts either through the engine bay or from underneath the vehicle and remove.

**Note:** In most instances these nuts will need to be loosened off or removed to allow the control arm bolt to be removed from the vehicle.

5. Remove the control arm bolts and remove the upper arm from the vehicle.
6. Before removing the bushes from the arm mark the position of the key ways on the arm to aid in correct installation of the 65057 bushes.
7. Remove the OE bushes from the arm and inspect arm for damage. Repair or replace as necessary.
8. Install the supplied 67057 bushes into the arm making sure the larger flange face faces outward and the bush is timed correctly (refer fig 2.)

**Note:** This can be identified by the **OUT** mark stamped on one end of the bush.

9. Apply a liberal amount of grease supplied to the outer flange faces of the bush and re-fit the arm into the brackets.
10. Re-fit the arm back into the vehicle and torque all bolts to manufacturers specifications.
11. Carry out wheel alignment.

**Note:** It is recommended to re-tension all bolts in approx 100km's of distance travelled.

Fig 1.

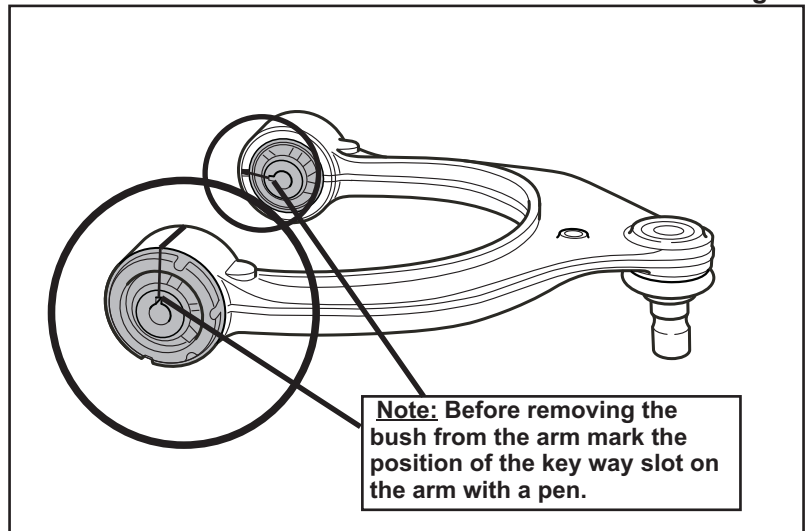

Fig 2.

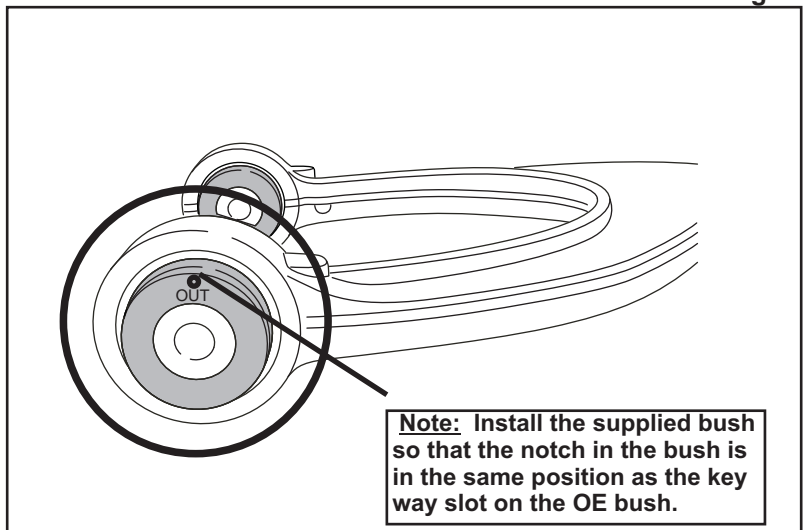
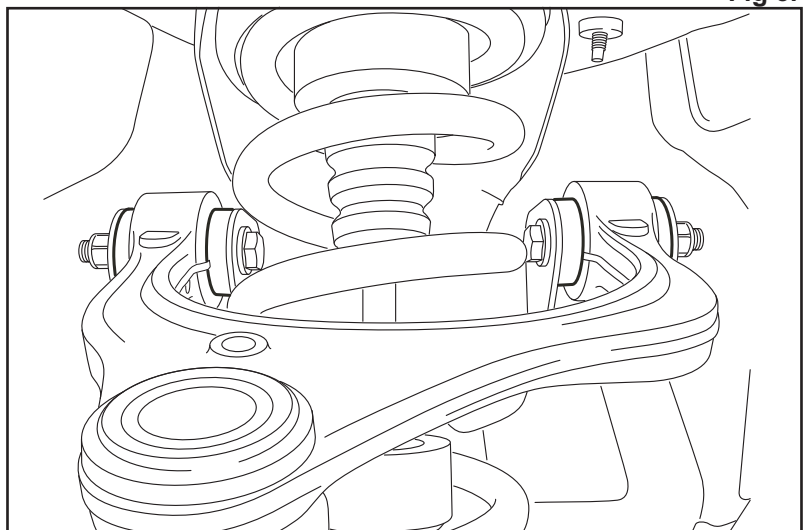

Fig 3.



# FITTING INSTRUCTIONS

## CASTER & CAMBER ADJUSTMENT KIT

Suits: FORD AU-FG FALCON / FAIRLANE / UTE

### Kit Contents

Complete Housings	x 2	3.0mm Shims	x 12	Self Locking Nuts	x 4
Replacement Bushes	x 2	1.5mm Shims	x 4	Crush Tubes	x 2



**N.B:** These instructions should be used in conjunction with workshop

**Note:** One kit adjusts one side only.

**For AU-FG std height to XR-** Use standard replacement kit - +/-1.5deg camber/caster kit.

**For XR height or lower** - Use +/-2.5deg camber/caster kit. Refer current catalogue for part number.

1. Perform normal pre-alignment procedures and then record the alignment angles.
2. From the previous information and the suggested alignment settings, determine whether one or both sides require adjustment.
3. Raise the front of the vehicle and support on chassis stands, remove the front wheels.
4. Remove the 4 original pivot mount retaining nuts inside the engine bay.
5. Swing out upper wishbone and fit pivots as direct replacement for the original pivot mounts.
6. It is now necessary to calculate the shim pack required. To do this the following information should assist. (Figures are only approximate).

**Note:** To obtain the initial figures as those with the O.E. pivots fit 1x6mm, 1x3mm & 1x1.5mm shims to both pivots. This should make the shim stack calculation easier. Eg, Housing +10.5mm shim pack = O.E. Pivot.

7. Proceed with alignment settings as suggested below, if desired settings cannot be achieved refer section

### To Alter Camber-Caster

**Suggested alignment angles\*:**

**Camber:** -0.75 deg +/-0.25 deg

**Caster:** +7 deg +/-0.25 deg

**Total toe:** 1mm total +/-0.5mm

**\*If these desired settings cannot be achieved refer to point 1**

### To Alter Camber:

- Removing shims at front and rear will move camber to the negative.
  - Adding shims at front and rear will move camber to the positive.
- Fitment or removal of 6.0mm shim from front and rear = 0.6 deg change.  
 Fitment or removal of 3.0mm shim from front and rear = 0.3 deg change.  
 Fitment or removal of 1.5mm shim from front and rear = 0.15 deg change.

### To Alter Caster:

- Removal of a front shim and reinstalling it in the rear moves caster to the negative.
  - Removal of a rear shim and reinstalling it in the front moves caster to the positive.
- Transfer a 6.0mm shim from one pivot to the other = 2 deg change.  
 Transfer a 3.0mm shim from one pivot to the other = 1 deg change.  
 Transfer a 1.5mm shim from one pivot to the other = 0.5 deg change.

8. Reinstall the top control arm with the relevant shim stacks in place. Ensure the correct mounting hole is used **refer fig 1**. Fit the new nuts supplied and tighten to 35Nm.
9. Refit the wheels, lower the vehicle and bounce the front of the vehicle to settle the new suspension into its normal ride position. Tighten the 4 Inner pivot bolts to 35Nm.
10. Recheck camber & caster. Adjust toe and road test vehicle. If desired specifications cannot be achieved, **refer point 1**.

**Note:** Additional shim kits are available.

45351-1.5mm	Pack 10	45353-3.0mm	Pack 10	45354-6.0mm	Pack 5
45350-1.5mm	Pack 100	45352-3.0mm	Pack 100	45355-6.0mm	Pack 50

**N.B:** It is recommended that a licenced workshop or trades person carry out the above procedure and that workshop manual and relevant safety procedures are followed in addition to the above.

